

Addressable



Loop Powered Sounder Beacon

Model : PTSASBX501 / PTSASBX501-3W

Datasheet

<http://www.pinetreesystems.com>



Outline

PTSSBR0 is designed to be used with Pinetree's range of Addressable Fire Alarm Control Panels and provides Audio Visual notification with high sound output during emergency. These devices are wall mounted and has two variants with tone selection.

Features & Benefits

- Low current consumption
- User selectable Tone*
- Easy installation and maintenance
- Loop powered / External power selection
- Excellent reliability high stability

Mechanical Specifications

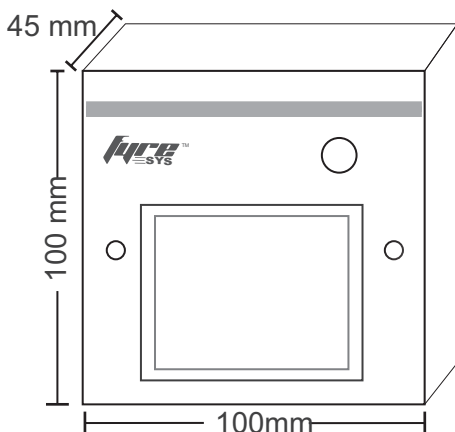

Technical Specification

Product Class	: Addressable
Sound Level	: 90 db @ 10 feet
Alarm Current	: 30mA
Operating Voltage	: 18-24V DC
Housing	: Mild Steel
Alarm Output	: Audio Visual
Operating Temperature	: -10°C to +55°C
Operating Humidity	: <95% Non Condensed

Dimensions

Height	: 100 mm
Width	: 100 mm
Depth	: 45 mm

Approvals

